

PITELUMEC

Thumper 50 DOWN THE HOLE HAMMER



THUMPER50 FOR HOLE DIAMETER 127 - 152MM

PNEUMEC THUMPER 50 5" DOWN THE HOLE HAMMER

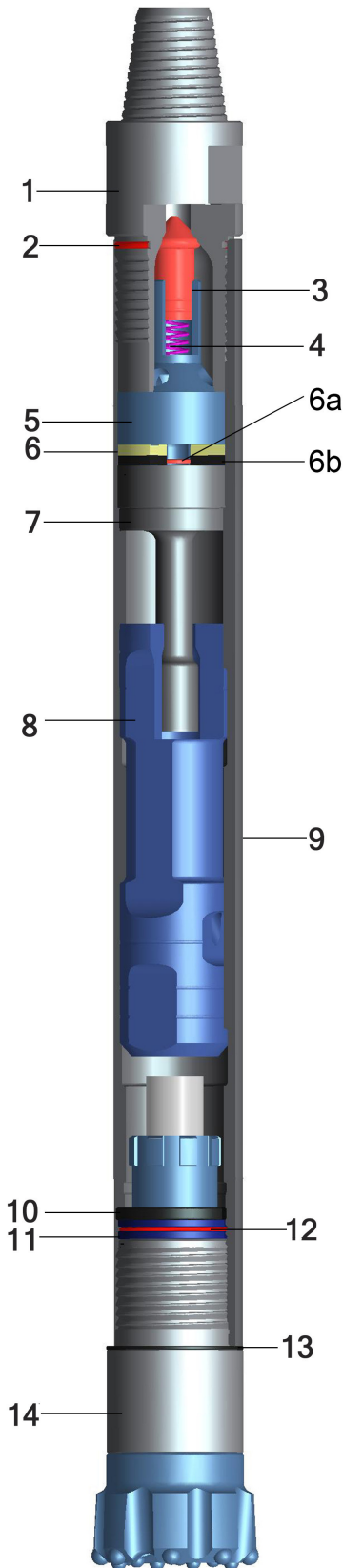

THUMPER 50 HAMMER PARTS LIST

1.	BACKHEAD 3-1/2" API REG PIN	HSP5S1T3M
2.	BACKHEAD "O" RING	HSP5S2
3.	CHECKVALVE	HSP5S3
4.	CHECK VALVE SPRING	HSP5S4
5.	VALVE CHEST	HSP5S5
6.	MAKE UP RING	HSP5S22
6a.	MAKE UP PLATE "O" RING	HSP5S6
6b.	MAKE UP PLATE	HSP5S23
7.	CONTROL TUBE	HSP5S8
8.	PISTON	HSP5S12350
9.	WEARSLEEVE	HSP5S18
10.	PISTON RING	HSP5S25
11.	BIT RETAINERS	HSP5S15350
12.	BIT RETAINER "O" RING	HSP5S16
13.	CHUCK RELEASE WASHER	HSP5S21
14.	CHUCK DHD350	HSP5S19350
15.	COMPLETE HAMMER DHD350	HAM5S350THP

THUMPER 50 HAMMER SPECIFICATIONS

DIAMETER	114MM
LENGTH	1110MM
PISTON WEIGHT	16KG
HAMMER WEIGHT	67KG
HOLE DIAMETER	127MM – 152MM
BACKHEAD CONNECTION	3-1/2" API REG PIN
SHANK TYPE	DHD350

THUMPER 50 HAMMER AIR CONSUMPTION

PRESSURE (BAR / PSI)	CFM	M ³ /MIN
10.3 / 150	260	7.4
13.8 / 200	390	11
17.2 / 250	575	16.3
24.1 / 350	820	23.2



PNEUMEC COMPANY LIMITED

1st Floor, Tin On Sing Comm. Bldg., 41-43 Graham St. Central, H.K.

Tel : (852) 2180 9922

Fax : (852) 2180 9982

Website : www.pneumec.com

email : info@pneumec.com